

Universal relief cone T3/480/425/P

Intended for:

- Protection of the shaft pipe of plastic manholes DN 400 and DN 425 with an outer diameter of up to max. DN/OD 475mm against damage in both vertical and horizontal planes.
- Indirect support of telescopic manholes/inlets in bituminous surfaces by placing a cone in the load-bearing layer of the surface structure - the cone provides support for the compacted layer of the road surface located between the bottom of the DN 425 telescopic manhole flange and the relief cone.
- Supports for reduction rings for installation on DN 400 and DN 425 manholes of 315 telescopic manholes located in group 1-3 areas
- Direct structural support of the T4/400/N protective cover by creating the T5/480/425/P protective set in areas not burdened with pedestrian and vehicle traffic, green areas, in track areas.

Universal relief cone T3/480/425/P (for telescopic finials) for plastic manholes

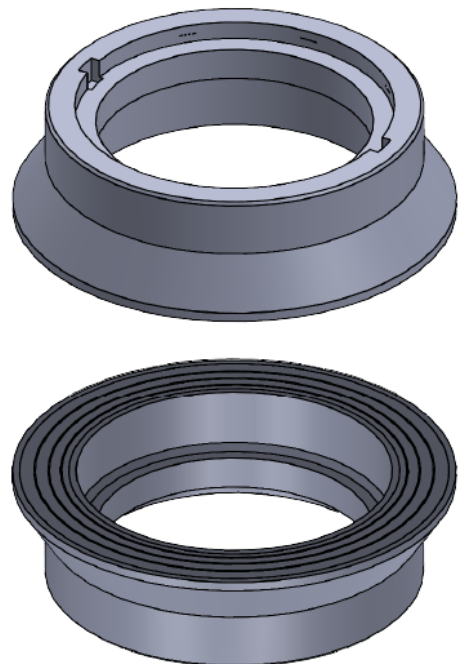
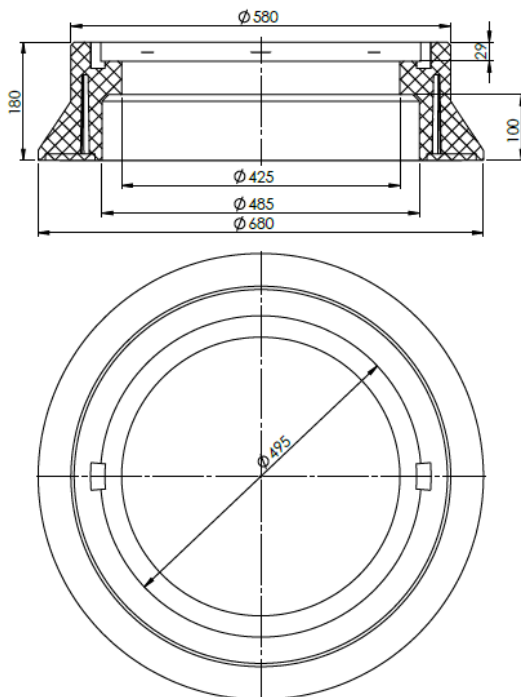

Index	DN(mm)	DZ(mm)	H(mm)	Weight (kg)	Class
T3/480/425/P	425/480	580/680	185	26	D400

3.Zastosowanie

Universal relief cone for securing plastic inspection and rain chambers DN400 and DN425 with an outer diameter of the shaft pipe (up to) DN/OD 475, topped with manholes/telescopic inlets DN 425. The construction of the cone provides both an additional cover for the connection of the telescopic pipe and the manhole shaft, as well as stress compensation in the near-surface area. In plastic rainwater chambers DN 400 and DN425, it supports the installation of adapters supporting the TVRT system for street inlets of the type 300x500, 500x500, 400x600 roadway, curb and roadway and self-levelling. The set consisting of the T3/480/425/P extraction cone and the adapter supporting the inlets from the TX/765 or TX/4052/10A product group ensures full relief, protection of the shaft of the plastic rainwater chamber from vertical and horizontal road loads and proper support of the inlet structure. The T3/480/425/P relief cone together with the T1/320/50 reducing ring can protect and relieve the shaft pipes of DN 400 manholes equipped with a sleeve seal (external diameter max. 480 mm) 400/315 and topped with manholes/telescopic inlets 315.

For use in communication engineering in accordance with the above-mentioned purpose in the field of public roads without limits, internal roads and railway engineering structures without limits. In the traffic areas of groups 1-4, in class D400 according to PN-EN 124-1: 2015-07.

Used in bitumen surfaces for relief and indirect support for telescopic manholes DN 425 manufactured by Orzechowscy, Magnaplast, Kaczmarek, Bohamet. 5cm between the bottom of the telescopic manhole flange and the top of the relief cone).

Technical parameters of T3/480/425/P - relief cone

Compressive strength. Class	400kN D400	PN-EN 124-1 07-2015
Tensile strength	3Mpa	PN-EN ISO 527-1:2012
Degree of resistance to frost in water	F150(-2%)	PB IBDIM PB/TB-1/23
Degree of frost resistance in 2% NaCl	F50(-2%)	PB IBDIM PB/TWm-36/98
Absorptivity	<0,2%	PN-EN ISO 62:2008
Mechanical loss	0,33 tg	
Hardness according to Shore	>46	PN-EN ISO 868:2005
Product dimensional tolerance	±5mm na średnicy, ±3mm na wysokości	
Support surface	1821 cm ²	
Thermal resistance	-30° C do +60° C	In continuous work conditions.

Short-term thermal resistance 170° C	2h	In the conditions of installation in the bituminous surface
PVC / PE material	80%	PN-EN 15346 2009
Product reference documents: National Technical Assessment No. IBDiM-KOT-2017/0047 3rd edition National Declaration of Performance No. 05 Code CN 39259090		
General assembly instructions: <ul style="list-style-type: none"> • around the shaft pipe(at the distance from the edge of the well ≥ 30 cm) make the thickening of the substructure for the finial in accordance with the rules resulting from ground conditions, compaction index, road structure type and traffic load category based on PN-ENV 1046 standard. • Conduct compaction by hand, in layers, every 15 cm or with light mechanical equipment, in layers, every 30 cm along the entire height of the well, evenly around the circumference and obtain the degree of ground compaction in accordance with the design, requirements of the manhole assembly instructions: • in areas with no traffic, the degree of density should be 92% on the Proctor scale, in pedestrian traffic routes (class A), the degree of density $\leq 95\%$, vehicle load (class D) $\geq 98\%$ on the Proctor scale. • in order to maintain proper compaction, it is recommended to stabilize the ground with cement in the near-surface area • the ground around the shaft pipe, under the relieving cone should be flat and free from point loads, consisting of gravel, sand, dry concrete (chippings, etc. are not allowed.) • the T3/480/425/P unloading cone is positioned centrally over the chamber opening without disturbing the foundation/compacted subsoil, leaving a free space of about 2÷3 cm between the top of the shaft pipe and the lower internal reducing edge of the cone, the subsoil under the cover body • Before starting the assembly works of the telescopic manhole DN 425 , check whether all the elements of the near-surface finial of the plastic manhole are structurally suited to the intended use: • whether the manhole has been properly adjusted to the ordinate, e.g. by cutting the shaft pipes and correct height foundation of the relief cone • whether an adequate margin of approx. 20 cm has been left/taken into account for the insertion of the telescopic pipe • whether the compaction of the foundation around the well is correct and adequate for the location of the relief cone foundation. • whether the appropriate height is maintained to the surface ordinate to allow for the installation of a telescopic manhole • inside the shaft pipe of the plastic manhole in the highest valley, a gasket should be installed (or a sealing and reducing collar with a lubricant) • insert a telescopic manhole into the stem pipe through the hole in the relief cone and place it on the cone (in the load-bearing layer of the pavement structure) • the manhole should be placed on and in the wearing course, both in the case of changing the elevation of the surface, it is possible to pull out the telescopic manhole from the cone and place a compacted bituminous layer in the space between the cone and the manhole and press the manhole in. 		
In traffic areas <p>around the finial of the plastic manhole make a road surface foundation based on breakstone (approx. 65-70%) and quick-setting cement masses (approx. 30-35%) or B35 concrete or asphalt mass / hot asphalt concrete commissioning should take into account the necessary time of complete cooling of the bituminous mass, allowing it to be put into service</p>		

Notes on installation conditions

During height adjustment of sewage wells with the use of plastic elements of the TVR T System, it is forbidden to:

- installing and assembling support adapters on incorrectly seated strain relief rings.
- use of ground materials for compaction of the substructure that do not comply with the recommendations of the manufacturer of manholes and materials other than those approved for use in road construction described in PN-S 02205, height adjustment, overlapping, placing point destructive elements under the cones
- laying the surface without making the correct foundation, filling and compacting the space around the finial and the manhole