

**An adapter supporting the TXP /425/K telescopic manhole**

**Intended for:**

- embedding of the telescopic manhole DN 425 (ø500mm) in the surface, transferring traffic loads from road traffic acting on the top of the manhole on a larger impact surface. .
- Protection of the telescopic pipe of the inspection well or rainwater well DN/OD 425 against damage both in the vertical and horizontal plane.
- Direct construction support:
  - telescopic manholes / inlets of plastic manholes DN 425 with the outer diameter of the body frame 500 mm in class D400 located with an oblique side in bituminous surfaces or made of pavement-type cubes

**Supporting adapter TXP / 425/K under manholes telescopic manholes for plastic chambers**

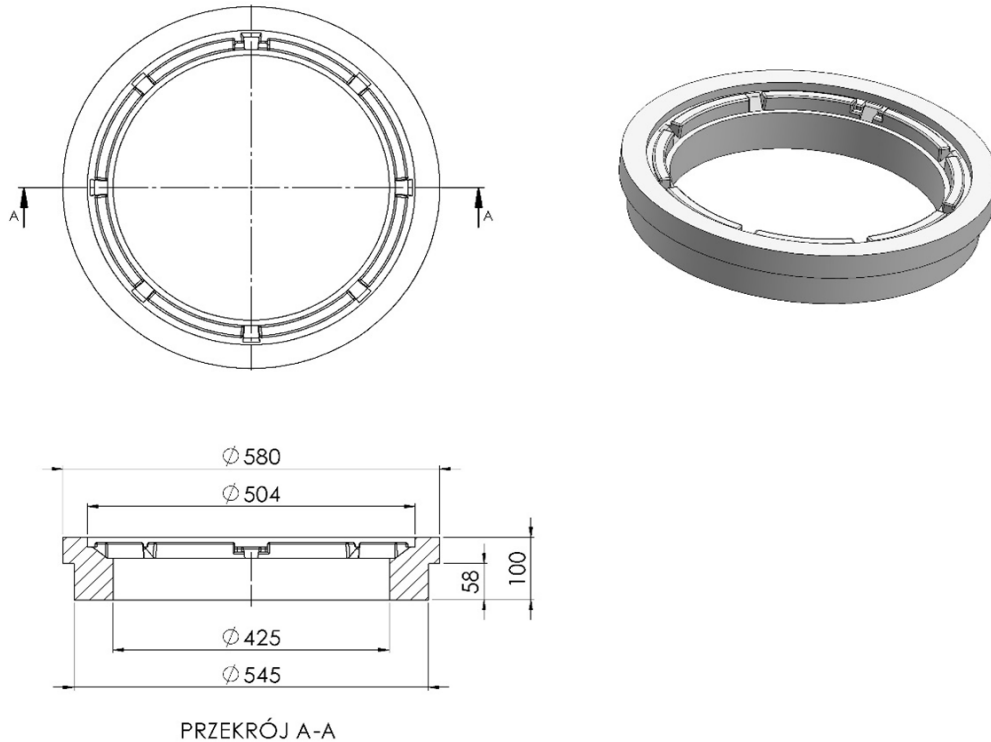

Index	DN(mm)	DZ(mm)	H(mm)	Weight(kg)	Class
TXP/425/K	425	564/570	76	9	D400

### 3.Application

An adapter supporting a manhole or telescopic manhole DN 425 with a body diameter of  $\varnothing 500$  mm in class D400. It is positioned directly under the manhole body in the pavement structure increasing the impact surface on the substructure, minimizing the collapse effect of the telescopic manhole. It can be a supporting element in the TXP / 480/425/230 relief set. The set of relieving and supporting elements ensures a full relief of the manhole elements from vertical and horizontal road loads.

For use in the communication engineering in accordance with the above-mentioned purpose in the field of public roads without limits , internal roads, road and railway engineering structures without limits .

In the traffic areas of groups 1-4, in class up to D400 according to PN-EN 124-1: 2015-07.

Used in:

- For telescopic manholes DN 425 ( $\varnothing 500$ mm) by Bohamet, Kaczmarek, Norson 110/1

#### Technical parameters of the TXP / 425 /K supporting adapter

Compressive strength. Class	400kN D400	PN-EN 124-1 07-2015
Tensile strength	3Mpa	PN-EN ISO 527-1:2012
Degree of resistance to frost in water	F150(-2%)	PB IBDIM PB/TB-1/23
Degree of frost resistance in 2% NaCl	F50(-2%)	PB IBDIM PB/TWm-36/98
Absorptivity	<0,2%	PN-EN ISO 62:2008
Mechanical loss	0,33 tg	
Hardness according to Shore	>46	PN-EN ISO 868:2005
Product dimensional tolerance	$\pm 5$ mm in diameter, $\pm 3$ mm in height	
Support surface	1119cm <sup>2</sup>	
Thermal resistance	-30°C do +60°C	In continuous work conditions.
Short-term thermal resistance 170°C	2h	In the conditions of installation in the bituminous surface
PVC / PE material	80%	PN-EN 15346 2009

Product reference documents:

National Technical Assessment No. IBDiM-KOT-2017/0047

National Declaration of Performance No. 09 / EW

Code CN 39259090

### General assembly instructions:

- Around the shaft well (at a distance of  $\geq 30$  cm from the edge), compact the base course for the topping in accordance with the rules resulting from the ground conditions, compaction index, road structure type and traffic load category based on PN-ENV 1046 standard.
- Perform the compaction by hand, in layers, every 15 cm or with light mechanical equipment, in layers, every 30 cm along the entire height of the well, evenly around the circumference and obtain the degree of soil compaction in accordance with the design, requirements of the manhole assembly instructions:
- In areas with no traffic, the degree of density should be 92% on the Proctor scale, in pedestrian traffic routes (class A) the degree of density should be  $\leq 95\%$ , in the vehicle load (class D) it should be  $\geq 98\%$  on the Proctor scale.
- In order to maintain the proper compaction, it is recommended to stabilize the soil with cement
- The ground / backfill around the shaft, sleeve, telescopic pipe should be free from point loads, consisting of gravel, sand, lean concrete (chippings and similar materials that damage the walls of plastic pipes are excluded).
- a supporting adapter TXP / 425 / K put on the telescopic pipe of the manhole DN 425 (the adapter can be glued to the bottom of the manhole)
- Before starting the assembly works of the DN 425 telescopic manhole check whether all the elements of the surface of the plastic manhole are structurally suited to the intended use:
  - whether the manhole has been properly adjusted to the ordinate, e.g. by cutting the shaft pipes,
  - whether there is an adequate margin of about 20 cm for inserting the telescopic pipe
  - whether the compaction of the substructure around the well is correct and adequate for the location.
  - whether the appropriate height is maintained to the surface ordinate, enabling the installation of the adapter with the telescopic manhole,
- a gasket (or reducing and sealing collar with a lubricant) should be installed inside the shaft of the plastic well in the highest valley
- insert a telescopic manhole into the shaft with a supporting adapter TXP/425
- in case of a change in the ordinate of the surface, it is possible to slide the telescopic manhole out of the adapter and place a compacted bitumen layer in the space between the adapter and the manhole and press the manhole on

### In traffic areas

- **around the top of the plastic manhole, up to the height of the adapter bottom, make the base of the road surface based on B35 concrete or asphalt mass / hot asphalt concrete (depending on the design )**
- commissioning should take into account the necessary time of complete cooling of the bituminous mass, allowing it to be put into service

### Notes on installation conditions

During the height adjustment of sewage wells with the use of plastic elements of the TVR T System, unacceptable is:

- installation and assembly of support adapters on incorrectly positioned relief cones
- use of ground materials for compaction of the foundation that do not comply with the recommendations of the manufacturer of manholes and materials other than those approved for use in road construction described in PN-S 02205, height adjustment, overlapping, placing destructive elements acting on a point under the adapters
- laying the surface without making the correct foundation, filling and compacting the space around the surface of the plastic manhole