

TXS/710/80 adapter/leading ring for self-leveling manholes

Intended for:

- Integration (through diameter and height connections) of a self-leveling manhole mounted on and in the bituminous surface with the near-surface finial of a concrete well with a DN600 or DN 625, DN 650, DN 700 manhole opening
- Integration (through diameter and height connections) of a self-leveling manhole mounted on and in the bituminous surface with the near-surface finial consisting of a relief cone T3 / 600, T3 / 615 BR, T3/680 BR mounted around a plastic manhole with a DN600, DN625 manhole opening
- Protection of the self-leveling manhole against horizontal displacement during operation

TXS/710/80 adapter / leading ring

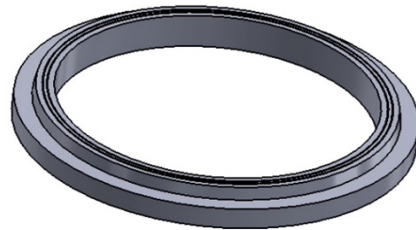
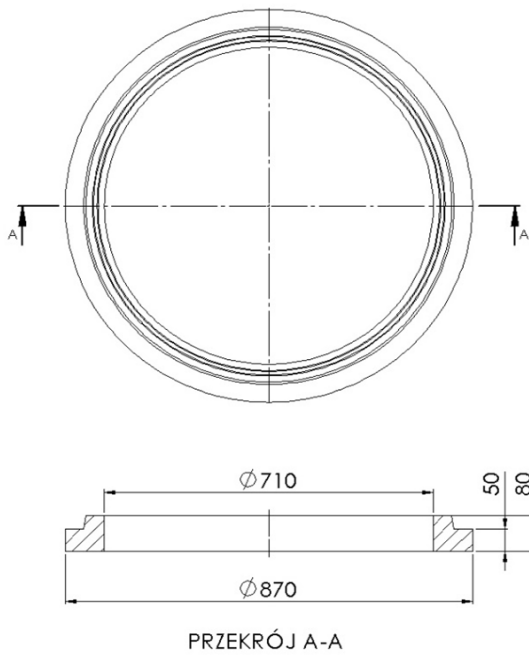

Index	DN(mm)	DZ(mm)	H(mm)	Weight(kg)	Class
TXS/710/80	710	870	80	18,2	D400

3.Application

Adapter / leading ring made of plastic TXS / 710/90 is a prefabricated element of the near-surface finial of wells ensuring height adjustment, connection of self-leveling manholes(with outer diameters of a leading pipe max. 695mm) with the well. It is placed on the compensation rings from the groups T1 / 600 and T1R / 625, T1/700. It enables a diametrical connection with a self-leveling manhole, the outer diameter of which is larger than the diameter of the compensation rings or the opening of the concrete manhole.

For use in the communication engineering in accordance with the above-mentioned purpose in the field of public roads without limits , internal roads, road and railway engineering structures without limits .

In the traffic areas of groups 1-4, in class up to D400 according to PN-EN 124-1: 2015-07.

4.Self-leveling manholes:

- Manufacturer STAMEI MAILEVEL series manhole catalog number: 104266, 104256
- Manufacturer SAINT GOBAIN (VIATOP M NIVEAU) Manhole number: CDVM60RGX40, CDVM60RG (in surfaces with a slight slope up to 3-4%)

Attention. Do not use for direct support of a self-leveling manhole. Horizontal storage on pallets.

Technical parameters of TXS/710/80 adapter / leading ring

Compressive strength. Class	400kN D400	PN-EN 124-1 07-2015
Tensile strength	3Mpa	PN-EN ISO 527-1:2012
Degree of resistance to frost in water	F150(-2%)	PB IBDIM PB/TB-1/23
Degree of frost resistance in 2% NaCl	F50(-2%)	PB IBDIM PB/TWm-36/98
Absorptivity	<0,2%	PN-EN ISO 62:2008
Mechanical loss	0,33 tg	
Hardness according to Schore	>46	PN-EN ISO 868:2005
Dimensional tolerance of the product	± 5mm in diameter, ± 3mm in height	
Support surface	2123cm ²	
Thermal resistance	-30° C do +60° C	In continuous work conditions.
Short-term thermal resistance 170° C	2h	In the conditions of installation in the bituminous surface
PVC / PE material	80%	PN-EN 15346 2009

General assembly instructions:

- Before starting the assembly works of a self-leveling manhole with the use of compensation rings, adapter rings / leading rings of the TVR T system , check whether the diameters (external and internal) are appropriate for the well, self-leveling manhole and whether all elements are structurally suited to the intended use; is there a sufficient height between the cover plate / reducer / manhole relief cone and the bituminous surface ordinate to allow the installation of a self-leveling manhole. This height should be at least 5 cm higher than the self-leveling manhole height.
- determine the necessary amount, the height of the compensation rings to make the height adjustment, taking into account the height of the leading adapter, the thickness of the repair layer and a minimum of 10 cm of bituminous layer under the manhole flange
- group T1 / 600 or T1R / 625, T1/700 compensating rings (recommended) may be installed on concrete elements of chambers, provided that the base on which they are to be installed is in good technical condition. They require an even, strong base / foundation.
- any defects, unevenness, damage, leaks should be repaired before the installation of compensating rings and adapter / leading rings by making a compensating and repair layer using cement quick-setting masses or resins with appropriate strength and operational parameters, dedicated by the manufacturer for repairing sewer manhole finials, anchoring manholes and drains
- the thickness of the repair layer should be in accordance with the recommendations of the manufacturer of quick-setting masses
- the finial of the well should be made in a tight manner, between all the components of the finial, i.e. compensating rings, leading adapter/ ring polymer adhesives and sealants should be used
- Place the rings centrally over the manhole opening, one on top of the other, pressing it firmly until the required adjustment height is achieved.
- place the leading adapter for the self-leveling manhole centrally on the compensation rings with the seal applied on the bottom
- check the height between the top of the adapter and the road surface ordinate (it should be 10cm)
- around the finial, to half the height of the leading adapter, make a road surface foundation based on breakstone (approx. 65-70%) and quick-setting cement masses (approx. 30-35%) or B35 concrete or asphalt mass / hot asphalt concrete
- Insert a metal formwork inside the adapter to make a bituminous load-bearing layer for the support of the self-leveling manhole
- the reconstruction of the road surface around the finial a metal formwork make in layers with appropriate compaction of each hot applied bituminous layer to the level of the pavement ordinance
- After removing the metal formwork from the opening, immediately insert a self-leveling manhole and roll it (press) into the compacted hot asphalt mass
- commissioning should take into account the necessary time of complete cooling of the bituminous mass, allowing it to be put into service

Notes on installation conditions

During the height adjustment of sewage chambers with the use of plastic elements of the TVR T System, it is unacceptable :

- installation and assembly of compensation rings on damaged elements of sewage manholes, on uneven, unrepaired, unprepared surfaces. Without providing full permanent support for compensation rings or adapter.
- use for height adjustment, putting on and placing point destructive elements (bars, plates, cut rings, etc.) on the compensation rings
- use of concrete mortars between the plastic compensation rings
- installation of self-leveling manholes that are structurally and dimensionally unsuited to the elements directly supporting the TVR T system
- Direct embedding of self-leveling manholes on adapters / guide rings without placing 10 cm thick asphalt layer between them
- making high adjustments above 30 cm only on the basis of rings with low dimensions
- laying the surface without making the correct foundation, filling and compacting the space around the finial