

T3/400N relief cone

Intended for:

- Transfer of traffic loads from vehicle traffic acting on the finials of manholes beyond the core of the DN / OD 400 plastic well onto the structural layers of ground or road substructure.
- Protection of the shaft of the plastic inspection or rainwater chamber DN / OD 400 against damage both in the vertical and horizontal plane. (for shaft pipes DN / OD max 420 mm)
- Direct structural support:
 1. compensation / reduction rings of the TVR T system from the T1 / 320 group for finials equipped with 315 telescopes

T3 / 400N relief cone for plastic chambers

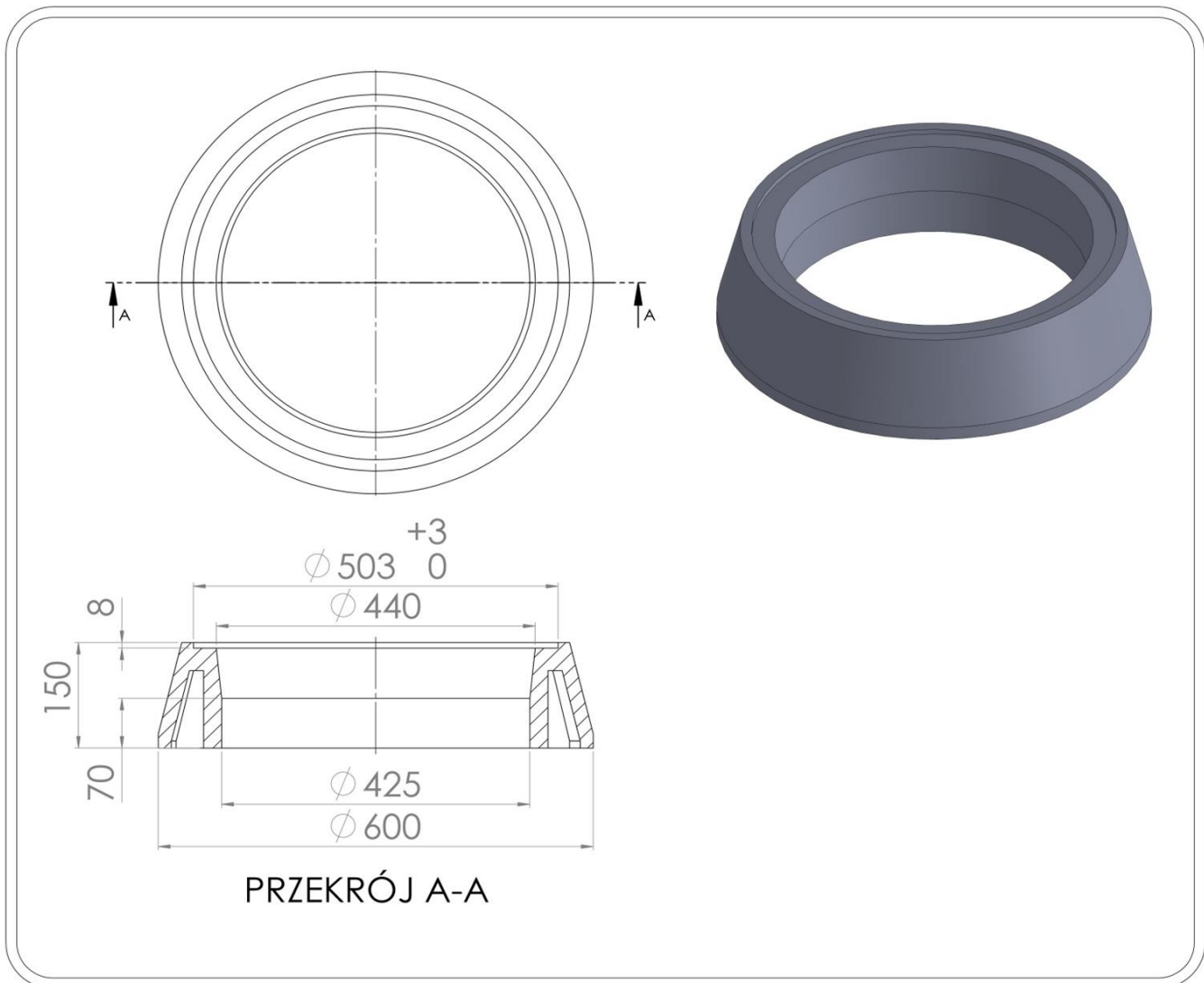

Index	DN(mm)	DZ(mm)	H(mm)	Weight(kg)	Class
T3/400N	425	600	150	17	D400

3.Application

The T3 /400 N relief cone with the reduction ring T1 / 320/50 enables full relief / protection of the shaft of the rising pipe of the plastic inspection chamber DN/OD 400, topped with a telescopic manhole 315, against traffic loads. Telescopic manhole 315 based directly on the road structure or additionally on a supporting adapter from the TXP / 315 or TXO / 315 group.

Element of the telescopic finial of the DN 425 plastic manhole, consisting of a cast-iron telescopic manhole with an outer diameter of the body flange of $\varnothing 500\text{mm}$, integrated with a DN 400 smooth pipe, mounted over the T3 / 400 / N relief cone. The cone located in the structural layers of the pavement increases the support surface for the telescopic manhole, protects the telescopic pipe against the influence of hot asphalt mass during assembly, compensates for some of the operational stresses. Recommended for telescopic tubes 700 mm high.

Producent Norson produkt właz i wpust na rurę 425

Producent Bohamet produkt właz i wpust na rurę 425

The manufacturer-- Norson, the product- manhole and drain for the pipe 425

The manufacturer Bohamet, the product- manhole and drain for the pipe 425

For use in communication engineering in accordance with the above-mentioned purpose in the field of public roads without limits, internal roads, and railway engineering structures without limits. In the traffic areas of groups 1-4, in class D400 according to PN-EN 124-1: 2015-07. It meets the conditions of suitability for use specified in PN-EN 14802: 2005

Technical parameters of T3 / 400 N relief cone

Compressive strength. Class	400kN D400	PN-EN 124-1 07-2015
Tensile strength	3Mpa	PN-EN ISO 527-1:2012
Degree of resistance to frost in water	F150(-2%)	PB IBDIM PB/TB-1/23
Degree of frost resistance in 2% NaCl	F50(-2%)	PB IBDIM PB/TWm-36/98
Absorptivity	<0,2%	PN-EN ISO 62:2008
Mechanical loss	0,33 tg	
Hardness according to Schore	>46	PN-EN ISO 868:2005
Product dimensional tolerance	$\pm 5\text{mm}$ in diameter, $\pm 3\text{mm}$ in height	
Support surface	D400-920 cm^2	
Thermal resistance	-30°C do +60°C	In continuous work conditions.
Short-term thermal resistance 170°C	2h	In the conditions of installation in the bituminous surface
PVC / PE material	80%	PN-EN 15346 2009

Product reference documents:

National Technical Assessment No. IBDiM-KOT-2017/0047 3rd edition

National Declaration of Performance No. 05 / EW / 22

Code CN 39259090

General assembly instructions:

- around the shaft pipe, (reducer) of the well cone (≥ 30 cm) make the thickening of the substructure for the finial in accordance with the rules resulting from ground conditions, compaction index, road structure type and traffic load category based on PN-ENV 1046 standard.
- Conduct compaction by hand, in layers, every 15 cm or with light mechanical equipment, in layers, every 30 cm along the entire height of the well, evenly around the circumference and obtain the degree of ground compaction in accordance with the design, requirements of the manhole assembly instructions:
- in areas with no traffic, the degree of density should be at least 92% on the Proctor scale, in pedestrian traffic routes (class A), the degree of density $\leq 95\%$, vehicle load (class D) $\geq 98\%$ on the Proctor scale.
- in order to maintain proper compaction, it is recommended to stabilize the ground with cement
- the ground under the relieving cone should be flat and free from point loads, consisting of gravel, sand, dry concrete (chippings, etc. are not allowed.)
- Before starting the assembly works of the T3 /400 N relieving cone, check whether all the elements of the near-surface finial of the plastic manhole are structurally suited to the intended use:
- whether the manhole has been properly adjusted to the ordinate, e.g. by cutting the shaft pipes
- is there a sufficient height between the top of the shaft pipe of well and the top of the relief cone of the chamber, at least 4 cm
- whether the compaction of the foundation around the well is correct and adequate for the location of the relief cone foundation.
- whether the appropriate height is maintained to the surface ordinate to allow for the installation of a manhole
- on the shaft of the plastic well from the inside, in the highest 'valley', a gasket (with a lubricant) or a reduction sleeve 400/315 should be installed on the upper edge of the shaft pipe
- we place the relief cone centrally over the well opening without disturbing the substructure / compacted substrate, leaving a free space of about 3-4 cm between the top of the shaft pipe and the upper edge of the cone (or a reduction ring up to 320mm)
- insert the telescopic pipe of the manhole through the hole in the reduction ring T1 / 320/50 into the shaft pipe of the well to the depth of 20 cm.
- around the telescopic pipe, over the relief cone and reduction ring, we make a compacted construction base of the surface that allows the installation of a telescopic manhole (also with a TXP supporting adapter)
- the finial of the well should be made in a tight manner, polymer bonding masses should be used between all the components of the finial, i.e. relief cone, shaft pipe, telescopic pipe of manhole , elastomeric gaskets should be used. Between the horizontal surfaces of the equalizing / reducing rings, the upper surface of the relief cone and the manhole cover, apply polymer bonding-sealing masses.

T3 / 400 N relief cone for indirect support of telescopic manholes DN 425

- The relief cone T3 / 400 acts as a supporting element of the telescopic manhole DN 425, placed directly under the manhole, which should be flush with the outer flange on the cone,
- Place the telescopic pipe of the manhole in the shaft pipe DN / OD 425 so that it is possible to compact and substructure the road surface under the cone connected to the manhole
- the cone with the manhole should be embedded in the surface structure referring to the grade line of the surface
- in the case of changing the grade line, renovation of the surface, the cone remains in the place of its earlier installation and the manhole is pulled up, the space between the manhole and the cone is filled with bituminous mass and the manhole is pressed into the surface

In traffic areas

- around the finial of the plastic manhole, up to 1/3 of the height of the relief cone , make a road surface foundation based on breakstone (approx. 65-70%) and quick-setting cement masses (approx. 30-35%) or B35 concrete or asphalt mass / hot asphalt concrete
- reconstruction of the road surface around the near-surface finial and the manhole is made in layers with appropriate compaction of each hot applied bitumen layer to the level of the pavement ordinate
- commissioning should take into account the necessary time of complete cooling of the bituminous mass, allowing it to be put into service

In green areas

- the relief cone with the protective cover should be raised above the ground level to protect against the inflow of surface water (at least 5-8 cm above the ground)

Notes on installation conditions

During height adjustment of sewage wells with the use of plastic elements of the TVR T System, it is forbidden to:

- installation and assembly of relief cones on an unprepared, uncompressed substructure around the manhole. Without providing full permanent support for the relief cone.
- use of ground materials for compaction of the substructure that do not comply with the recommendations of the manufacturer of manholes and materials other than those approved for use in road construction described in PN-S 02205, height adjustment, overlapping, placing point destructive elements under the cones
- laying the surface without making the correct foundation, filling and compacting the space around the finial and the manhole