

An adapter supporting the TXP / 315 / PO telescopic manhole

Intended for:

- Distribution of traffic loads coming from road traffic which act on the tops of plastic manholes over a larger surface of the soil layer, road base, pavement structure.
- Protection of the telescopic pipe of the inspection well or rainwater well DN / ID 315 against damage both in the vertical and horizontal plane. Used in DN 315, DN 400, DN425 manholes.
- Direct construction support:
- telescopic manholes / inlets of plastic manholes DN 315 with the outer diameter of the body frame 370 x 370 mm in class A15 ÷ D400 located with an oblique side in bituminous surfaces

Supporting adapter TXP / 315 / PO under manholes telescopic manholes for plastic chambers.

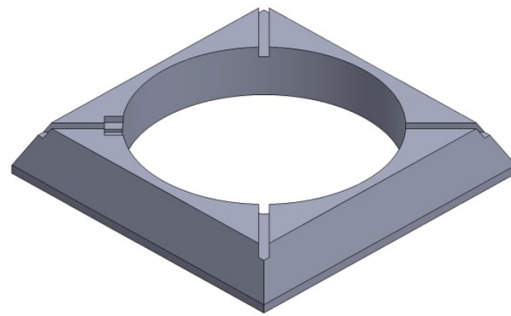
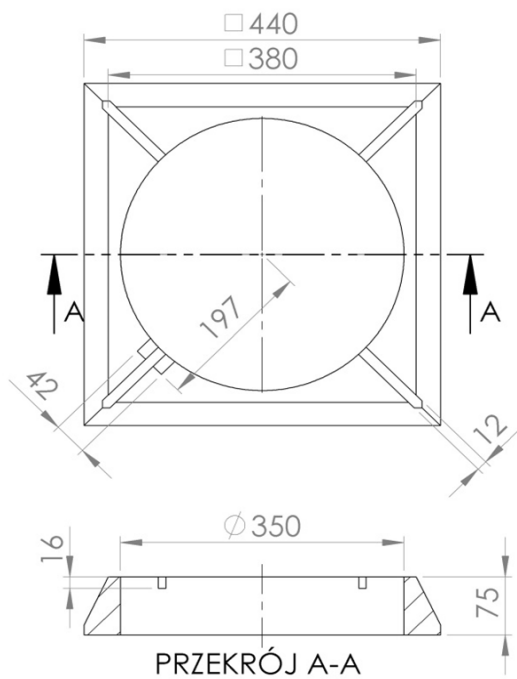

Index	DN(mm)	DZ(mm)	H(mm)	Weight(kg)	Class
TXP/315/PO	350	440	75	7,7	D400

3.Application

An adapter increasing the support surface for manholes and telescopic drains 315 corps of 370 x 370 mm in class B125 and D400.

It is positioned directly under the manhole body in the road structure. It is recommended to stick the adapter to the telescopic inlet before its assembly (glue and sealant by Wurth),

An additional support for the adapter can be the T1 320 ring. The adapter can be used with other types of dn315 telescopic manholes and inlets indirectly by placing 3-5 cm of asphalt over the adapter.

A supporting adapter for supporting telescopic manholes and DN315 drains installed in the bituminous surface.

Intended for square support bodies of manholes with the outer dimensions of the collar 370 x 370mm and the outer diameter of the telescope 350 mm (e.g. of the Orzechowscy foundry)

For use in the communication engineering in accordance with the above-mentioned purpose in the field of public roads without limits , internal roads, road and railway engineering structures without limits .

In the traffic areas of groups 1-4, in class up to D400 according to PN-EN 124-1: 2015-07.

Technical parameters of the supporting adapter TXP/315/PO

Compressive strength. Class	400kN D400	PN-EN 124-1 07-2015
Tensile strength	3Mpa	PN-EN ISO 527-1:2012
Degree of resistance to frost in water	F150(-2%)	PB IBDIM PB/TB-1/23
Degree of frost resistance in 2% NaCl	F50(-2%)	PB IBDIM PB/TWm-36/98
Absorptivity	<0,2%	PN-EN ISO 62:2008
Mechanical loss	0,33 tg	
Hardness according to Shore	>46	PN-EN ISO 868:2005
Product dimensional tolerance	± 5mm in diameter, ± 3mm in height	
Support surface	920cm ²	
Thermal resistance	-30° C do +60° C	In continuous work conditions.
Short-term thermal resistance 170° C	2h	In the conditions of installation in the bituminous surface
PVC / PE material	80%	PN-EN 15346 2009

Product reference documents:

National Technical Assessment No. IBDiM-KOT-2017/0047 3rd edition

National Declaration of Performance No. 09 / EW / 22

Code CN 39259090

General assembly instructions:

- Around the shaft well (at a distance of ≥ 30 cm from the edge), compact the base course for the topping in accordance with the rules resulting from the ground conditions, compaction index, road structure type and traffic load category based on PN-ENV 1046 standard.
- Perform the compaction by hand, in layers, every 15 cm or with light mechanical equipment, in layers, every 30 cm along the entire height of the well, evenly around the circumference and obtain the degree of soil compaction in accordance with the design, requirements of the manhole assembly instructions:
- In areas with no traffic, the degree of density should be 92% on the Proctor scale, in pedestrian traffic routes (class A) the degree of density should be $\leq 95\%$, in the vehicle load (class D) it should be $\geq 98\%$ on the Proctor scale.
- In order to maintain the proper compaction, it is recommended to stabilize the soil with cement
- The ground / backfill around the shaft, sleeve, telescopic pipe should be free from point loads, consisting of gravel, sand, lean concrete (chippings and similar materials that damage the walls of plastic pipes are excluded).
- Put the supporting adapter on the telescopic pipe so that the bottom of the manhole rests on the adapter (you can glue the manhole with the adapter with glue + sealant)
- Before starting the assembly works of the telescopic manhole with the TXP/315/PO adapter, check whether all the elements of the surface of the plastic manhole are structurally suited to the intended use:
- whether the well has been properly adjusted to the ordinate, e.g. by cutting the shaft pipes,
- whether there is an adequate margin of about 20 cm for inserting a telescopic pipe,
- whether the compaction of the foundation around the well is correct and adequate for the location of the relief cone foundation,
- whether the appropriate height is maintained to the surface ordinate, enabling the installation of the adapter with the telescopic manhole,
- a gasket (or reducing and sealing collar with a lubricant) should be installed inside the shaft of the plastic well in the highest valley
- insert a telescopic manhole into the shaft with an adapter on the appropriate height what enables proper compaction under the adapter
- in case of a change in the ordinate of the surface, it is possible to slide the telescopic manhole out of the adapter and place a compacted bitumen layer in the space between the adapter and the manhole and press the manhole on
- **In traffic areas**
- around the top of the plastic manhole, up to the height of the adapter bottom, make the base of the road surface based on breakstone (approx. 65-70%) and quick-setting cement masses (approx. 30-35%) or B35 concrete or asphalt mass / hot asphalt concrete
- commissioning should take into account the necessary time of complete cooling of the bituminous mass, allowing it to be put into service

In green areas

- the supporting adapter stabilizes and secures the settlement of the telescopic manhole

Notes on installation conditions

During the height adjustment of sewage wells with the use of plastic elements of the TVR T System, unacceptable is:

- installation and assembly of support adapters on an unprepared, uncompacted substructure around the well
- use of ground materials for compaction of the foundation that do not comply with the recommendations of the manufacturer of manholes and materials other than those approved for use in road construction described in PN-S 02205, height adjustment, overlapping, placing destructive elements acting on a point under the adapters
- laying the surface without making the correct foundation, filling and compacting the space around the surface of the plastic manhole