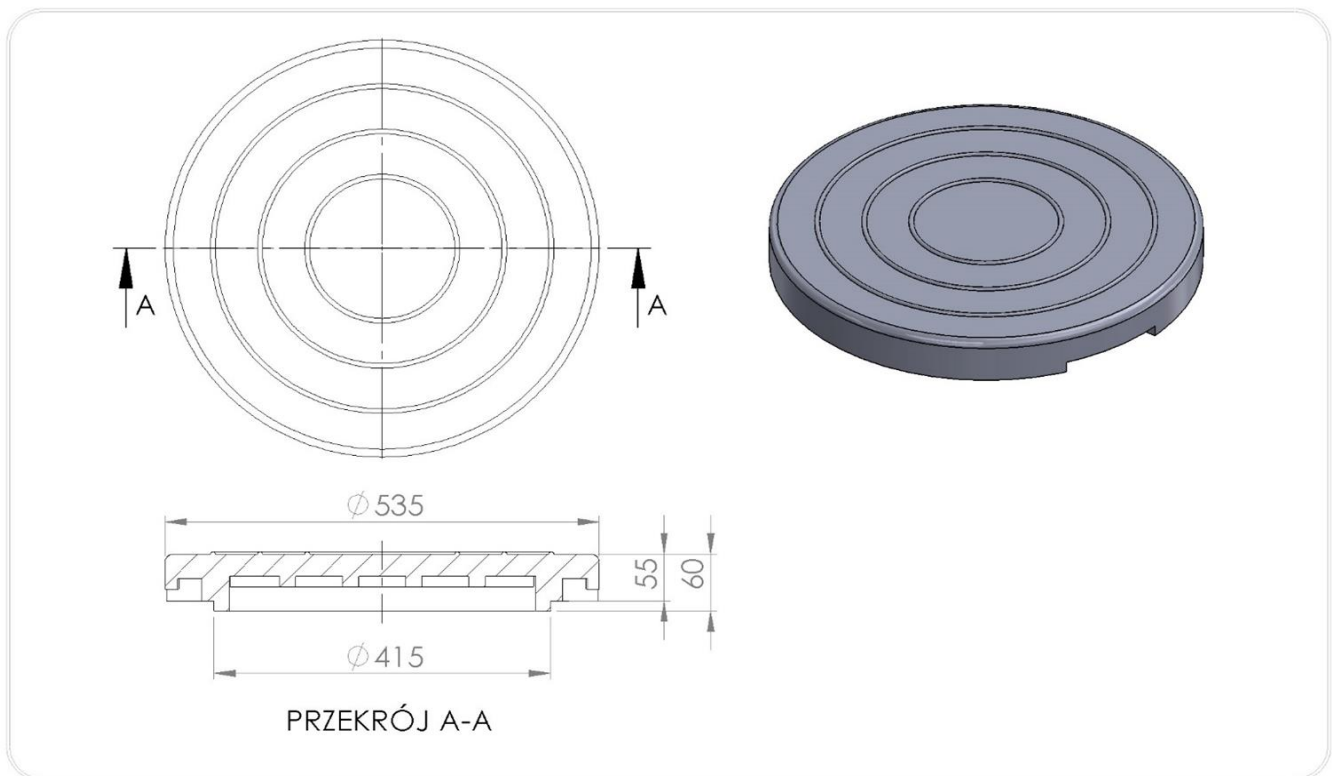

Protective cover T4 400

Intended for:

- Protection of plastic wells with an inspection opening DN 315 equipped with a relief cone T3 / 400 against contamination, rainwater inflow
- Temporary protection of concrete wells / rain water drains DN 450mm DN 500

Protective cover for DN 400 manholes.

Technical parameters of the T4 400 protective cover

Compressive strength. Class	200kg	PN-EN 124-1 07-2015
Tensile strength	3Mpa	PN-EN ISO 527-1:2012
Degree of resistance to frost in water	F150(-2%)	PB IBDIM PB/TB-1/23
Degree of frost resistance in 2% NaCl	F50(-2%)	PB IBDIM PB/TWm-36/98
Absorptivity	<0,2%	PN-EN ISO 62:2008
Mechanical loss	0,33 tg	

Hardness according to Shore	>46	PN-EN ISO 868:2005
Dimensional tolerance of the product	± 5mm in diameter, ± 3mm in height	
Support surface	- cm ²	
Thermal resistance	-30° C do +60° C	In continuous work conditions.
Short-term thermal resistance 170° C	2h	In the conditions of installation in the bituminous surface
PVC / PE material	80%/weight 13,6kg	PN-EN 15346 2009
<p>Product reference documents: National Technical Assessment No. IBDiM-KOT-2017/0047 3rd edition National Declaration of Performance No. 03 / EW / 22 Code CN 39259090</p>		
<p>General assembly instructions:</p> <ul style="list-style-type: none"> • T4 400 protective covers with the T3/400 (DN/ID425mm) plastic relief cone should be raised above the level of the surrounding ground, the surface of about 8 cm in order to protect the sewage system, septic tanks against the inflow of surface waters. • The location of the chamber with a protective cover should preclude accidental running of vehicles onto the chamber. • The protective cover can be additionally secured against opening by screwing the cover to the relief cone. 		