

TX/765/395/80/P Adapter for street drains

Intended for:

- direct placement of flanged street drains class D400, type 400x600 (outer diameter of the drain collar at least 580mm) and 500x500 without flanged drains, curb and curb-road drains 400x600
- Direct (after preparation) placement of D400 class 400x600 inlets with a ¾ flange (at curbs)
- reduction of the diameter of concrete manholes DN 450 (according to DIN 4052) and DN 500, and plastic manholes DN 425 and DN 600
- centralizing the outflow of surface water to receiving wells
- strain relief and protection of plastic manholes DN / ID 365

TX/765/395/80/P Adapter for street drain

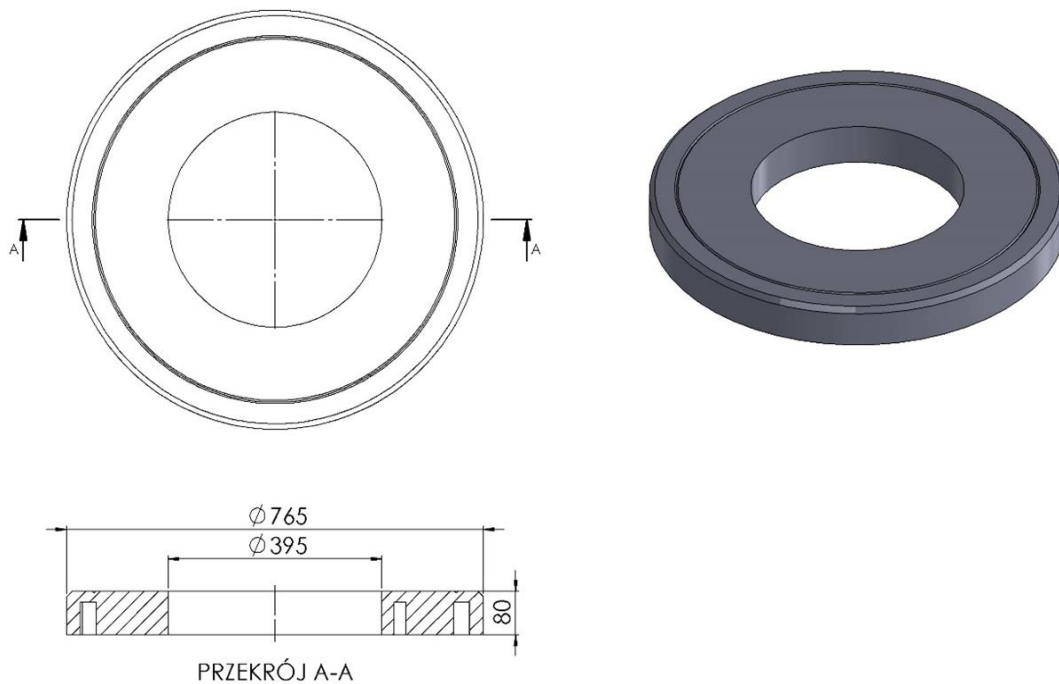

Index	DN(mm)	DZ(mm)	H(mm)	Weight(kg)	Class
TX/765/395/80/P	395	765	80	28	D400

3. Application:

TX/765/395/80/P Adapter for street drain made of plastic is a prefabricated element in the D400 class for the construction of tight surface finials of sewage drains and other devices for the collection of surface water. Adapters are a direct supporting / load-bearing elements for the sewage drain ensuring full support for the drain frame, tightness of the finial and trouble-free support for the surface around the drain. They are an element of height adjustment of the manhole and street drain. They are placed on concrete intermediate rings of DN 450 and DN 500 street drains (also on cover plates based on relief rings) and compensation rings type T1 / 435, T1 / 500, T2 / 500.

On the T3/425, T3/600, T3/615 relief cones, they form the basis for the installation of flanged sewage drains.

In plastic rainwater chambers DN400 and DN425 the TX / 765/395 /80 adapter is used both as an element relieving the manhole and as an element supporting the 500x500, 400x600 drains.

For use in the communication engineering in accordance with the above-mentioned purpose in the field of public roads without limits , internal roads, road and railway engineering structures without limits .

In the traffic areas of groups 1-4, in class up to D400 according to PN-EN 124-1: 2015-07.

Attention. 1. To support without flanged street drains type 400x600, only in areas group 2, according to PN-EN 124-1: 2015-07. In low risk areas, e.g. drain bays.

Technical parameters of the TX/765/395/80P adapter

Compressive strength. Class	400kN D400	PN-EN 124-1 07-2015
Tensile strength	3Mpa	PN-EN ISO 527-1:2012
Degree of resistance to frost in water	F150(-2%)	PB IBDIM PB/TB-1/23
Degree of frost resistance in 2% NaCl	F50(-2%)	PB IBDIM PB/TWm-36/98
Absorptivity	<0,2%	PN-EN ISO 62:2008
Mechanical loss	0,33 tg	
Hardness according to Schore	>46	PN-EN ISO 868:2005
Dimensional tolerance of the product	± 5mm in diameter, ± 3mm in height	
Support surface	2485cm ²	
Thermal resistance	-30° C do +60° C	In continuous work conditions.
Short-term thermal resistance 170° C	2h	In the conditions of installation in the bituminous surface
PVC / PE material	80%	PN-EN 15346 2009

Product reference documents:

National Technical Assessment No. IBDiM-KOT-2017/0047 3rd edition

National Declaration of Performance No. 07 / EW / 22

Code CN 39259090

General assembly instructions:

- before starting the assembly works with the TVR T system compensating rings, check whether the diameters (external and internal) are appropriate for a given manhole and that all elements are structurally suited to the intended application
- determine the necessary amount, the height of the compensation rings for height adjustment, taking into account the angle of inclination, the height of the TX/765/395/80 supporting adapter, the height of the sewage drain, the thickness of the repair layer
- T1 /500 compensation rings may be installed on the upper elements of concrete chambers, provided that the ground on which they are to be installed is in good technical condition. They require the provision of an even, strong base / foundation.
- any defects, unevenness, damage, leaks should be repaired before the installation of compensating rings by making a compensating and repair layer with the use of cement quick-setting masses or resins with appropriate strength and operating parameters, dedicated by the manufacturer to repair the finials of sewage manholes, anchoring manholes
- the rain water drain finial should be made in a tight manner, polymer adhesives and sealants should be used between all the elements of the top, i.e. compensation rings, supporting adapter, drain
- place the rings centrally over the manhole, one on top of the other, pressing firmly until the required adjustment height is achieved.
- the elements of the immediate vicinity of the street drain, such as edges, curbs, drainage elements, etc. should be matched to the drainage device. The integrity of the construction of the surface finial should be maintained as much as possible.
- on the compensation rings, place the supporting adapter for the street drain, with the sealing on the bottom
- under and around the finial make reconstruction / substructure of the road surface based on breakstone (approx. 65-70%) and cement quick-setting masses (approx. 30-35%)
- reconstruction of the road surface around the finial is made in layers with appropriate compaction (in accordance with the design)
- commissioning should take into account the necessary time of complete cooling of the bituminous mass, allowing it to be put into service

Notes on installation conditions

During height adjustment of sewage wells and sewage drains with the use of plastic elements of the TVR T System, it is forbidden to:

- compensation rings/ supporting adapters installation on damaged elements of sewage chambers, on uneven, unrepaired, unprepared surfaces, not providing full permanent support for compensation rings or an adapter
- use any placing point destructive elements (bars, plates, cut rings, etc.) for height adjustment via putting them on the compensation rings
- use of concrete mortars between the plastic compensation rings
- install manholes that are structurally and dimensionally unadjusted to the elements directly supporting the TVR T system
- make high adjustments above 25cm only on the rings with low dimensions
- laying the surface without making the correct foundation, filling and compacting the space around the finial