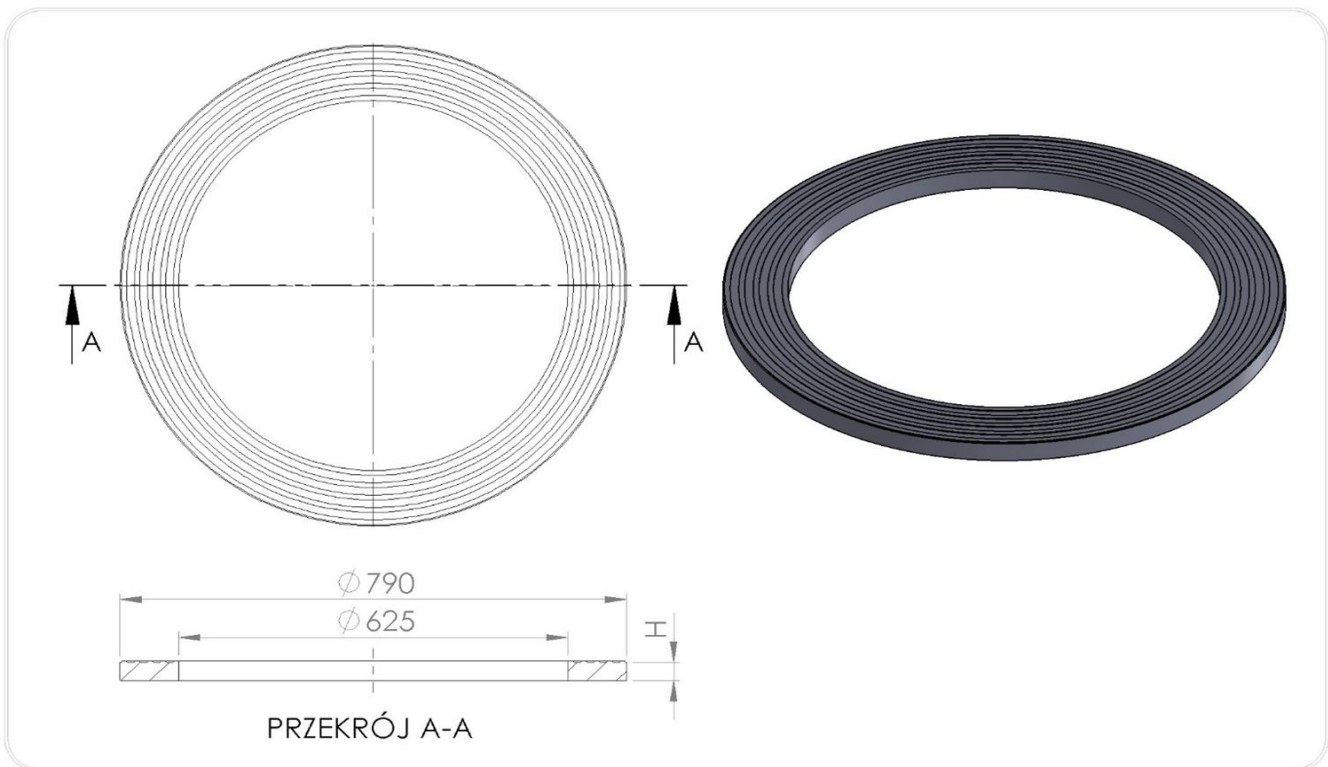

T1/625 Compensation rings
Intended for:

- height adjustment of concrete chambers with a DN 600 mm and DN 625 mm manhole.
- height adjustment of plastic manholes on T3/600, T3/615, T3/680 relief cones
- direct foundation of flanged manholes class D400, inclusive of DN 600 (with the outer diameter of the manhole base flange maximum 785 mm)
- direct foundation of the leading adapters (TXS) of the TVR T system for self-leveling manholes the positioning of manholes and self-leveling drains class D400 (with the outer diameter of the leading flange 613 mm)
- foundation of TVR T system elements due to directly support square, octagonal shaped manholes T04 foundation slabs with body foot diameters bigger than 805mm
- height adjustment of manholes in an alternating system with concrete rings made according to DIN 4034 part 1 and part 2

T1/625 Compensation rings

Tabela nr1.

Index	DN(mm)	DZ(mm)	H(mm)	Weight(kg)	Class
T1/625/15	625	790	15	4,2	D400

T1/625/30	625	790	30	6,6	D400
------------------	------------	------------	-----------	------------	-------------

3. Application:

Plastic compensation rings from the T1 / 625 assortment group are an element of the top-surface of sewage manholes ensuring height adjustment of the manhole in the range from 15 to 300 mm. They are laid on concrete reducers or cover plates of sewage chambers with a DN 600 and DN 625, on compensation rings from the T1 / 625 assortment group and on manhole and on T3 / 600, T3/615, T3/680 relief cones.

- They constitute a direct basis for the assembly of standard manholes DN600 to class D400, with the outer diameter of the body base max. \varnothing 785mm.
- They are an element of height adjustment of the final made on the basis of concrete rings with the outer diameter 625mm, AVR type.

The T1 / 625/15 compensation ring placed on the T1R / 625 compensation rings (by aligning the height to the rim height) allows the use of manholes with an outer diameter of the body foot ≥ 840 mm, as well as other elements of the TVR T system, e.g. foundation slabs under manholes with square or octagonal footing etc. For manholes that require direct support of a supporting element providing full support for the foot of the manhole body, placed on compensating rings T1R / 625.

For use in communication engineering in accordance with the above-mentioned purpose in the field of public roads without limits, internal roads, road and railway engineering structures without limits. In the traffic areas of groups 1-4, in class D400 according to PN-EN 124-1: 2015-07

Technical parameters of T1/625 compensation rings

Compressive strength. Class	400kN D400	PN-EN 124-1 07-2015
Tensile strength	3Mpa	PN-EN ISO 527-1:2012
Degree of resistance to frost in water	F150(-2%)	PB IBDIM PB/TB-1/23
Degree of frost resistance in 2% NaCl	F50(-2%)	PB IBDIM PB/TWm-36/98
Absorptivity	<0,2%	PN-EN ISO 62:2008
Mechanical loss	0,33 tg	
Hardness according to Schore	>46	PN-EN ISO 868:2005
Product dimensional tolerance	± 5 mm in diameter, ± 3 mm in height	
Support surface	1898 cm ²	

Thermal resistance	-30° C do +60° C	In continuous work conditions.
Short-term thermal resistance 170° C	2h	In the conditions of installation in the bituminous surface
PVC / PE material	80%	PN-EN 15346 2009

Product reference documents:

National Technical Assessment No. IBDiM-KOT-2017/0047 3rd edition

National Declaration of Performance No. 03 / EW / 22

Code CN 39259090

General assembly instructions:

- before starting the assembly works with the TVR T system compensating rings, check whether the diameters (external and internal) are appropriate for a given manhole and that all elements are structurally suited to the intended application
- determine the necessary amount, the height of the compensation rings for height adjustment, taking into account the angle of inclination (or the height of the supporting element), the height of the manhole, the thickness of the repair layer
- T1 / 625 compensation rings may be installed on the upper elements of concrete chambers, provided that the ground on which they are to be installed is in good technical condition. They require the provision of an even, strong base / foundation.
- any defects, unevenness, damage, leaks should be repaired before the installation of compensating rings by making a compensating and repair layer with the use of cement quick-setting masses or resins with appropriate strength and operating parameters, dedicated by the manufacturer to repair the finials of sewage manholes, anchoring manholes
- the thickness of the repair layer should be in accordance with the recommendations of the manufacturer of quick-setting compounds
- the surface of the manhole finial should be made in a tight manner, polymer adhesives and sealants should be used between all the elements of the top, i.e. compensation rings, supporting element, manhole
- place the rings centrally over the manhole, one on top of the other, pressing firmly until the required adjustment height is achieved.
- on the compensation rings, place the leading adapter for the self-leveling manhole or the support element for the manholes listed in table 1 (with the sealing on the bottom)
- around the top, make reconstruction / substructure of the road surface based on breakstone (approx. 65-70%) and cement quick-setting masses (approx. 30-35%)
- reconstruction of the road surface around the near-surface finial is made in layers with appropriate compaction (in accordance with the design)
- commissioning should take into account the necessary time of complete cooling of the bituminous mass, allowing it to be put into service

Notes on installation conditions

During height adjustment of sewage wells and drains with the use of plastic elements of the TVR T System, it is forbidden to:

- compensation rings installation on damaged elements of sewage chambers, on uneven, unrepaired, unprepared surfaces, not providing full permanent support for compensation rings.
- use any placing point destructive elements (bars, plates, cut rings, etc.) for height adjustment via putting them on the compensation rings
- use of concrete mortars between the plastic compensation rings
- install manholes that are structurally and dimensionally unadjusted to the elements directly supporting the TVR T system
- make high adjustments above 25cm only on the rings with low dimensions
- laying the surface without making the correct foundation, filling and compacting the space around the finial and the manhole