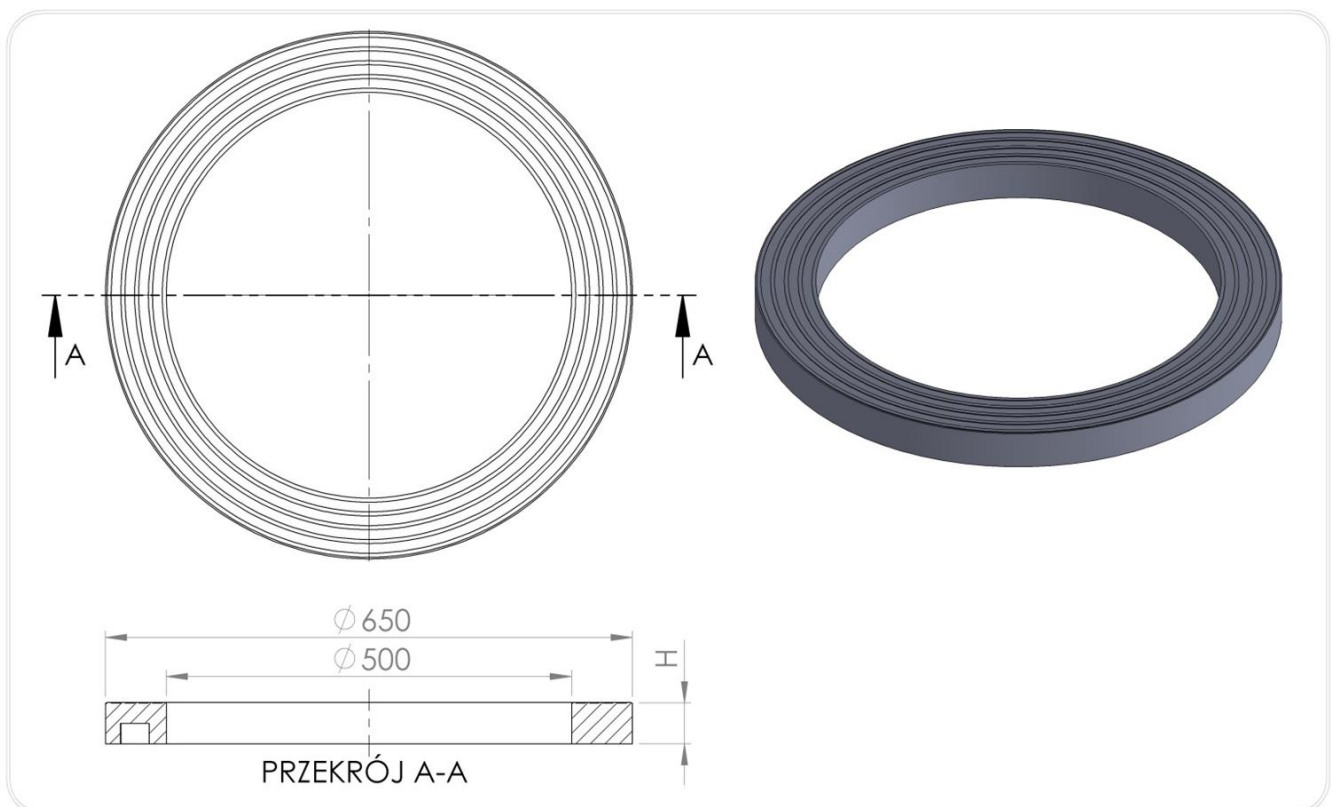

**Compensation rings - T1/500**
**Intended for:**

- height adjustment of concrete manholes DN 500 mm (street drains)
- height adjustment of DN / ID 425mm plastic manholes on T3 / 425 relief cones
- direct placement of fully flanged street drains class D400, type 400 x 600 (Ø flange minimum 620mm)
- direct placement of adapters from the group (TX) of the TVR T system supporting street drains: roadway, full flange and ¾ flange (400 x 600); 500 x 500 drains, road and curb drains
- the placement of the D400 class DN500 manholes (Dz. w 505, Dz. z 645mm)
- strain relief and covers of plastic manholes DN / ID 425 (DN / OD max. 495mm)

**T1/500 Compensation rings**

Index	DN(mm)	DZ(mm)	H(mm)	Weight(kg)	Class
T1/500/10	500	650	10	2,7	D400
T1/500/15	500	650	15	3	D400
T1/500/30	500	650	30	5,6	D400
T1/500/50	500	650	50	7,4	D400
T1/500/100	500	650	100	14,3	D400

### 3. Application:

Plastic compensation rings from the T1 /500 assortment group are a prefabricated element of the top-surface of street manholes ensuring height adjustment of the well, street drain . They are laid on concrete intermediate rings of DN 500 and DN 450 street drains (also on cover plates based on strain relief rings) and on the relief cones T3 / 425. They are the basis for the assembly of supporting adapters, such as:

- TX/4052/10A
- TX/4052/10AP
- TX/6060/75
- TX/650/395/P
- TX/765/395/80
- TX/765/410/80
- TX/765/420/470/BK
- TX/765/500/80

T1 / 500 Group Compensation Rings can directly support 400 x 600 (solid) type flanged street inlets.

For use in communication engineering in accordance with the above-mentioned purpose in the field of public roads without limits, internal roads, and railway engineering structures without limits. In the traffic areas of groups 1-4, in class D400 according to PN-EN 124-1: 2015-07

Attention. Do not use for direct support **without flanged** street drains of the type 300x300, 500x500, 400x600, road and curbdraains with a concrete body 450x450.

#### Technical parameters of T1 / 500 compensation rings

Compressive strength. Class	400kN D400	PN-EN 124-1 07-2015
Tensile strength	3Mpa	PN-EN ISO 527-1:2012
Degree of resistance to frost in water	F150(-2%)	PB IBDIM PB/TB-1/23
Degree of frost resistance in 2% NaCl	F50(-2%)	PB IBDIM PB/TWm-36/98
Absorptivity	<0,2%	PN-EN ISO 62:2008
Mechanical loss	0,33 tg	
Hardness according to Schore	>46	PN-EN ISO 868:2005
Product dimensional tolerance	± 5mm in diameter, ± 3mm in height	
Support surface	920cm <sup>2</sup>	
Thermal resistance	-30° C do +60° C	In continuous work conditions.
Short-term thermal resistance 170° C	2h	In the conditions of installation in the bituminous surface
PVC / PE material	80%	PN-EN 15346 2009

**Product reference documents:**

National Technical Assessment No. IBDiM-KOT-2017/0047 3rd edition

National Declaration of Performance No. 02 / EW / 22

Code CN 39259090

**General assembly instructions:**

- before starting the assembly works with the TVR T system compensating rings, check whether the diameters (external and internal) are appropriate for a given manhole and that all elements are structurally suited to the intended application
- determine the necessary amount, the height of the compensation rings for height adjustment, taking into account the angle of inclination (or the height of the supporting element), the height of the manhole, the thickness of the repair layer
- T1 /500 compensation rings may be installed on the upper elements of concrete chambers, provided that the ground on which they are to be installed is in good technical condition. They require the provision of an even, strong base / foundation.
- any defects, unevenness, damage, leaks should be repaired before the installation of compensating rings by making a compensating and repair layer with the use of cement quick-setting masses or resins with appropriate strength and operating parameters, dedicated by the manufacturer to repair the finials of sewage manholes, anchoring manholes
- the thickness of the repair layer should be in accordance with the recommendations of the manufacturer of quick-setting compounds
- the surface of the manhole finial should be made in a tight manner, polymer adhesives and sealants should be used between all the elements of the top, i.e. compensation rings, supporting element, manhole
- place the rings centrally over the manhole, one on top of the other, pressing firmly until the required adjustment height is achieved.
- the elements of the immediate vicinity of the street drain, such as edges, curbs, drainage elements, etc. should be matched to the drainage device. The integrity of the surface of the gully top should be maintained as much as possible.
- place an appropriate adapter on the compensating rings to support the street drain with the sealing on the bottom or directly sewage drain type 400x600 full (flange  $\varnothing$  min.620mm),
- around the top, make reconstruction / substructure of the road surface based on breakstone (approx. 65-70%) and cement quick-setting masses (approx. 30-35%)
- reconstruction of the road surface around the near-surface finial is made in layers with appropriate compaction (in accordance with the design)
- commissioning should take into account the necessary time of complete cooling of the bituminous mass, allowing it to be put into service

**Notes on installation conditions**

During height adjustment of sewage wells and sewage drains with the use of plastic elements of the TVR T System, it is forbidden to:

- compensation rings installation on damaged elements of sewage chambers, on uneven, unrepaired, unprepared surfaces, not providing full permanent support for compensation rings.
- use any placing point destructive elements (bars, plates, cut rings, etc.) for height adjustment via putting them on the compensation rings
- use of concrete mortars between the plastic compensation rings
- install manholes that are structurally and dimensionally unadjusted to the elements directly supporting the TVR T system
- make high adjustments above 25cm only on the rings with low dimensions
- **laying the surface without making the correct foundation, filling and compacting the space around the finial and the manhole**