

### T1/435 Compensation rings

**Intended for:**

- height adjustment of concrete manholes DN 450 mm (according to DIN 4052, street drains)
- height adjustment of DN / ID 400mm plastic manholes on T3 / 315 (ID 365mm) and T3 / 400 (ID 425mm) relief cones
- direct support for adapters from the group (TX) of the TVR T system supporting telescopic manholes: roadway, full flange and ¾ flange (400x600); 500x500 drains, road and curb drains
- the placement of the D400 class DN 425 traditional manholes with a round foot  $\varnothing$  max. 570 mm
- reduction of the diameter of the DN / ID 400 (DN / OD max. 420 mm) plastic manholes with the T3 / 400 / N or T3 / 400 relief cone in the finial with the 315 telescopic manhole
- strain relief and covers of the shaft pipes of plastic manholes DN / ID 400 (DN / OD max. 425mm) with a reduction ring T1 / 320/50 in the finial with a telescopic manhole 315

### T1/435 Compensation rings

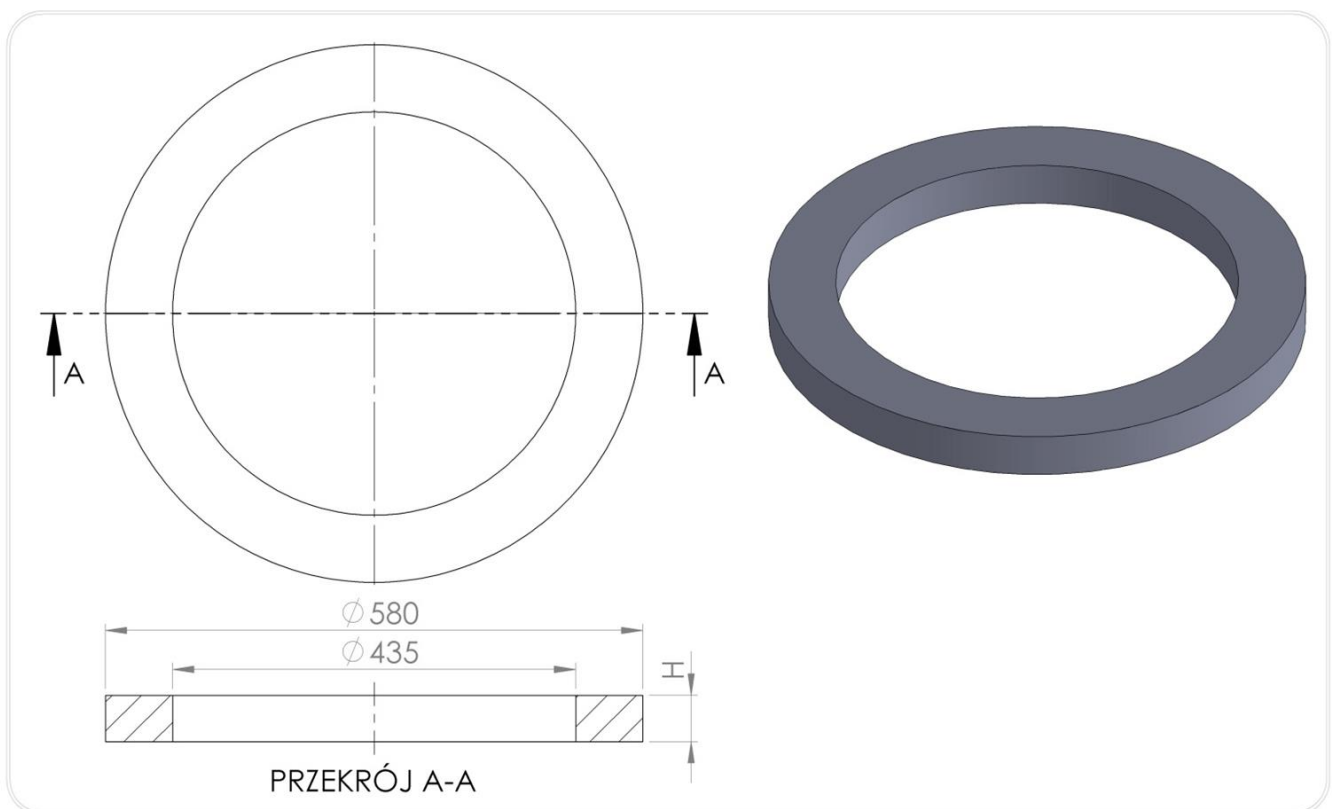

Index	DN(mm)	DZ(mm)	H(mm)	Weight(kg)	Class
T1/435/10	435	580	10	2,2	D400
T1/435/15	435	580	15	2,5	D400
T1/435/30	435	580	30	4,4	D400

<b>T1/435/50</b>	<b>435</b>	<b>580</b>	<b>50</b>	<b>6,5</b>	<b>D400</b>
<b>T1/435/100</b>	<b>435</b>	<b>5800</b>	<b>100</b>	<b>13,7</b>	<b>D400</b>

**3. Application:**

Plastic compensation rings from the T1 /435 assortment group are an element of the top-surface of street chambers, street manholes ensuring height adjustment of the well, street drain . They are laid on concrete intermediate rings of DN 450 street drains and on the relief cones T3 / 400. They are the basis for the assembly of supporting adapters, such as:

- TX/4052/10A
- TX/4052/10AP
- TX/6060/75
- TX/650/395/P
- TX/765/395/80
- TX/765/410/80

The group T1 /435 compensating rings can also be used as leading rings for manholes and self-leveling drains with the outer diameter of the leading flange pipe  $\varnothing$  408 ÷ 425 mm

For use in communication engineering in accordance with the above-mentioned purpose in the field of public roads without limits, internal roads, and railway engineering structures without limits. In the traffic areas of groups 1-4, in class D400 according to PN-EN 124-1: 2015-07

**Attention.** Do not use for direct support without flanged street drains type 300x300, 400x600, curb-road drains with a concrete body 450x450 due to unfavorable support surfaces.

**Technical parameters of T1 / 435 compensation rings**

Compressive strength. Class	400kN D400	PN-EN 124-1 07-2015
Tensile strength	3Mpa	PN-EN ISO 527-1:2012
Degree of resistance to frost in water	F150(-2%)	PB IBDIM PB/TB-1/23
Degree of frost resistance in 2% NaCl	F50(-2%)	PB IBDIM PB/TWm-36/98
Absorptivity	<0,2%	PN-EN ISO 62:2008
Mechanical loss	0,33 tg	
Hardness according to Schore	>46	PN-EN ISO 868:2005
Product dimensional tolerance	± 5mm in diameter, ± 3mm in height	
Support surface	1157 cm <sup>2</sup>	
Thermal resistance	-30° C do +60° C	In continuous work conditions.
Short-term thermal resistance 170° C	2h	In the conditions of installation in the bituminous surface
PVC / PE material	80%	PN-EN 15346 2009

**Product reference documents:**

National Technical Assessment No. IBDiM-KOT-2017/0047 3rd edition

National Declaration of Performance No. 02 / EW / 22

Code CN 39259090

**General assembly instructions:**

- before starting the assembly works with the TVR T system compensating rings, check whether the diameters (external and internal) are appropriate for a given manhole and that all elements are structurally suited to the intended application
- determine the necessary amount, the height of the compensation rings for height adjustment, taking into account the angle of inclination (or the height of the supporting element), the height of the manhole, the thickness of the repair layer
- T1 /435 compensation rings may be installed on the upper elements of concrete chambers, provided that the ground on which they are to be installed is in good technical condition. They require the provision of an even, strong base / foundation.
- any defects, unevenness, damage, leaks should be repaired before the installation of compensating rings by making a compensating and repair layer with the use of cement quick-setting masses or resins with appropriate strength and operating parameters, dedicated by the manufacturer to repair the finials of sewage manholes, anchoring manholes
- the thickness of the repair layer should be in accordance with the recommendations of the manufacturer of quick-setting compounds
- the surface of the manhole finial should be made in a tight manner, polymer adhesives and sealants should be used between all the elements of the top, i.e. compensation rings, supporting element, manhole
- place the rings centrally over the manhole, one on top of the other, pressing firmly until the required adjustment height is achieved.
- the elements of the immediate vicinity of the street drain, such as edges, curbs, drainage elements, etc. should be matched to the drainage device. The integrity of the surface of the gully top should be maintained as much as possible.
- place an appropriate adapter on the compensating rings to support the street drain with the sealing on the bottom
- place the drain on the adapter by centering the outflow holes of the drain, the adapter and the rainwater drain
- use a spirit level to control the correctness of the height adjustment of the drain to the ordinate of the surface surrounding the drain (tolerance - 5mm, the edge of the inlet frame below the ordinate of the pavement)
- drains with holes for anchoring, can be anchored to the adapter with screws  $\varnothing 8 \div 10$ mm
- around the top, make reconstruction / substructure of the road surface based on breakstone (approx. 65-70%) and cement quick-setting masses (approx. 30-35%)
- reconstruction of the road surface around the near-surface finial is made in layers with appropriate compaction (in accordance with the design)
- commissioning should take into account the necessary time of complete cooling of the bituminous mass, allowing it to be put into service

**Notes on installation conditions**

During height adjustment of sewage wells and sewage drains with the use of plastic elements of the TVR T System, it is forbidden to:

- compensation rings installation on damaged elements of sewage chambers, on uneven, unrepaired, unprepared surfaces, not providing full permanent support for compensation rings.
- use any placing point destructive elements (bars, plates, cut rings, etc.) for height adjustment via putting them on the compensation rings
- use of concrete mortars between the plastic compensation rings
- install manholes that are structurally and dimensionally unadjusted to the elements directly supporting the TVR T system
- make high adjustments above 25cm only on the rings with low dimensions
- laying the surface without making the correct foundation, filling and compacting the space around the finial and the manhole

